



Schindler 3000

Stylish, functional and flexible





A flexible solution that unifies form and function. An all-round elevator applicable to multiple building types, with outstanding architectural flexibility for car, door and shaft dimensions. Swiss precision engineering and latest technologies assure a smooth and safe user experience.



Schindler 3000

Stylish, functional and flexible

Schindler 3000 offers a large variety of design and dimensional combinations, and can be tailored to multiple applications in any urban environment. Select from a full spectrum of styles, colors and options to find the best possible match for your building.

Schindler 3000 is part of Schindler's new, modular-platform product range for all residential and commercial buildings, from low-to mid-rise, and from basic to sophisticated requirements, worldwide.

Key figures

Capacity	320 - 1350 kg
Travel height	Up to 70 m
Stops	Max 24 stops
Speed	1.0 - 1.6 m/s
Drive system	Machine-room-less, eco-friendly regenerative drive technology, frequency controlled
Group size	Up to 6 cars
Entrances	One- or two-sided
Interior	3 interior design lines, fresh wall colors and wide range of fixtures, and bare car option

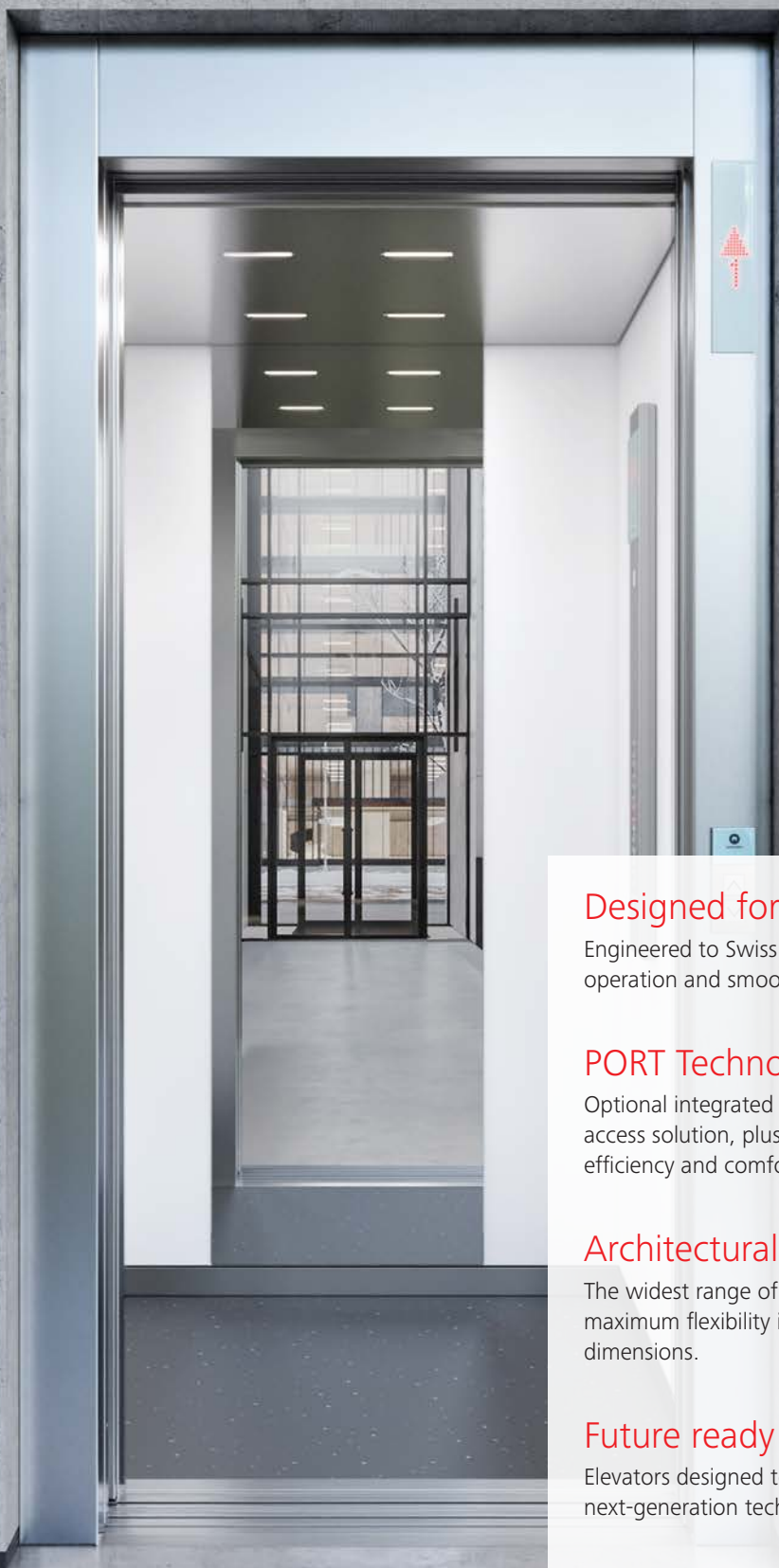

Designed for comfort

Engineered to Swiss standards for 24/7 operation and smooth ride comfort.

PORT Technology

Optional integrated building security access solution, plus increased elevator efficiency and comfort.

Architectural flexibility

The widest range of applications, plus maximum flexibility in car and shaft dimensions.

Future ready

Elevators designed to interface with next-generation technologies.

Multiple design options

Three full design lines to complement your building interior, or chose your own design.

Designed for comfort – built to last

Engineered to Swiss standards

Schindler 3000 is designed, engineered and rigorously tested to ensure smooth, quiet and economical operation throughout your elevator's long life cycle, for every application, and in any environment.



Latest technologies, greater comfort

Variable frequency drive systems deliver perfectly controlled power to traction machines and door drives, extending component lifetimes and increasing energy efficiency. Schindler Suspension Traction Media is light and long-lasting, enabling the use of smaller traction machines that reduce both energy consumption and noise and vibration levels in the car.

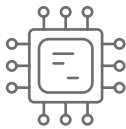

State-of-the-art digital controller

Schindler's scalable (universal) elevator controller offers more flexibility in number of openings, number of stops, and car group size. What's more, Schindler's innovative EPIC absolute positioning system improves both reliability and maintainability.



High-quality – at every level

Contact-free sensors assure millimeter-precise leveling with the floor for safe, seamless movement of passengers and goods in and out of the elevator.



Innovative drive technology

Schindler 3000 is equipped as standard with our innovative, regenerative drive technology. The system is designed to reduce travel energy by up to 30% compared to conventional technology.



Excellent ecological performance

Improving energy efficiency is essential to reduce the environmental impact of elevators and the buildings they serve. Regenerative drive, LED lighting and stand-by mode while parked, are standard eco-friendly features in all Schindler 3000 elevators, aiming to achieve the highest energy-efficiency rating class A according to ISO 25745-2*.

*The classification always refers to a specific customer configuration. Usage pattern, load capacity, customer specific options and site conditions influence the final rating.

Access control and transit intelligence

The revolutionary PORT Technology

All Schindler 3000 elevators are enabled for our revolutionary PORT Technology, with all the advantages of reduced travel time in elevators, higher passenger traffic capacity, and the potential for full building security and personalized access. PORT makes buildings more attractive, more efficient, and more valuable.



Learn more about
PORT Technology
www.schindler.com/port



Architectural flexibility

Less space, more capacity

Schindler 3000 has outstanding architectural flexibility for car, door and shaft dimensions. Less space for components, more room for you to use profitably.

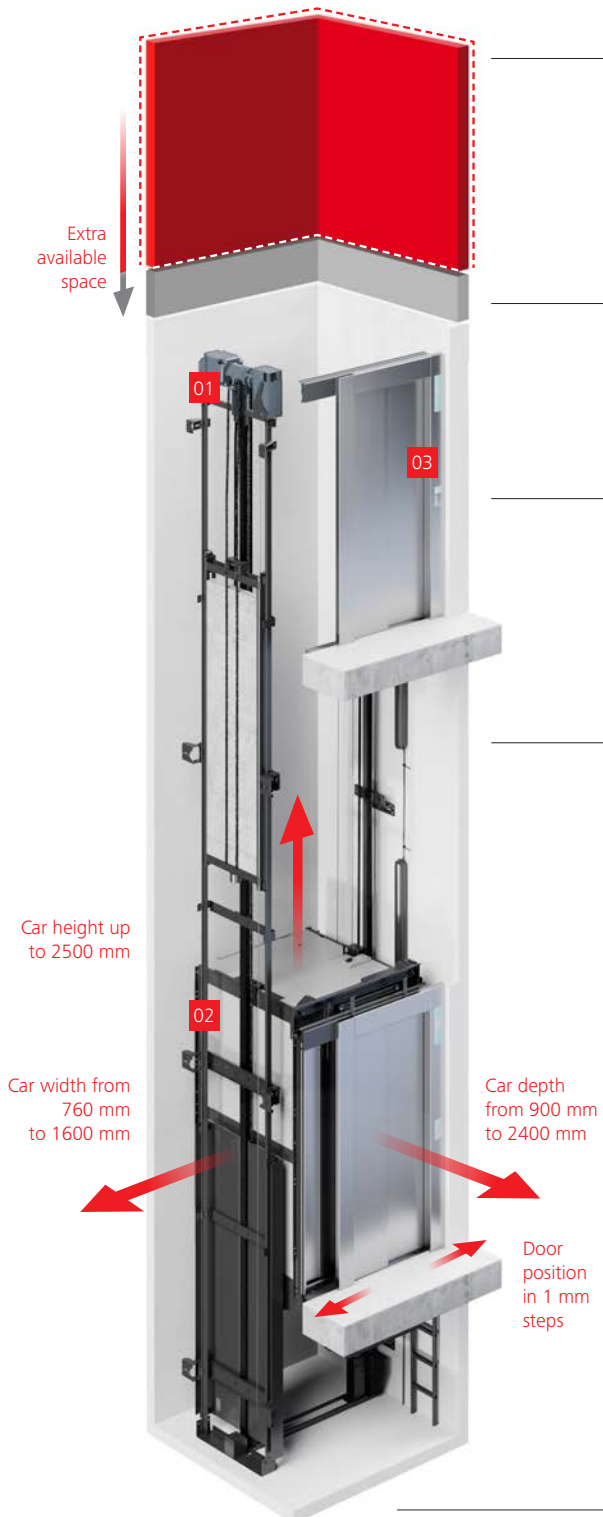

Machine-room-less design

All main drive, traction and control equipment sits in the shaft, leaving architects and designers free to use the extra space for more productive purposes. And thanks to the compact gearless machine, a larger car can be fitted into a standard shaft space, reducing headroom space and pit depth.

Reduced headroom

It offers even more room for you making the installation highly flexible.

Built-in inspection and test panel

Modular system, scalable car and door dimensions

We can adjust car dimensions for you in any direction in 10 mm increments. Schindler 3000 car width is available from 760 mm to 1600 mm, car depth from 900 mm to 2400 mm, and car height can right up to 2500 mm.

Doors can be sized and positioned with millimeter accuracy. The door width is adjustable in 50 mm increments for heights from 2000 mm to 2400 mm, with a choice of telescopic (T2) or center-opening doors (C2, C4) and single or double (through-loading).

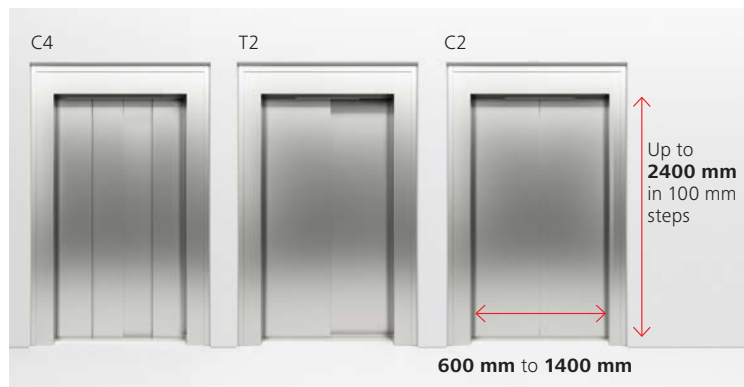

Reduced pit depth

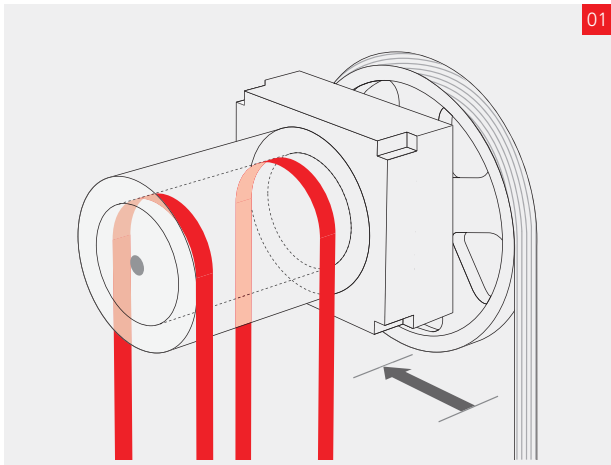

01

Smaller motor and traction sheave

Schindler's Suspension Traction Media (STM) system guarantees a quieter, smoother ride and does not require any oil or lubricant. STM also saves shaft space because of the smaller motor and traction sheave – 70% smaller than traditional systems. For passengers that means a better ride, while building owners will appreciate the increased reliability and efficiency.

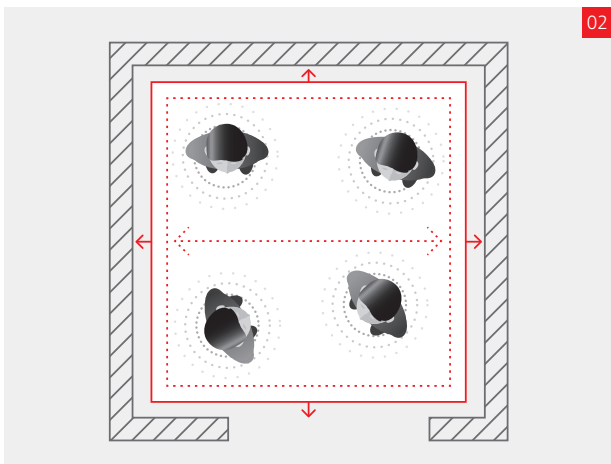

02

More usable building space

Less space for components, more usable building space and more room for passengers. Schindler 3000's innovative platform ensures that a standard-sized shaft can carry a wider car with bigger load capacity.



03

Built-in inspection and test panel

Schindler 3000's inspection and test panel is built directly into a standard door frame at the top landing. This solution simplifies elevator installation, provides easy access, and saves space.

Future ready

Schindler elevators designed for next-generation technologies

Benefit from our tools, solutions and latest innovations to support you through the entire product life cycle of your elevator. Our elevators are designed to use state-of-the-art technologies from planning to operation.



Plan & Design online

With just a few clicks, you can plan the right elevator for your building. Our online **Plan & Design Tool** provides you with recommendations, comprehensive product specifications and detailed layout drawings. All of these are compatible with **Building Information Modeling (BIM)** standards, and with our **Project Cloud** you can share your projects with us.



Innovation in installation

Schindler's new **INEX (Installation Excellence)** method not only reduces construction preparation and resources for our customers, it also improves safety and efficiency on site.

Our autonomous self-climbing robot system – **Schindler's Robotic Installation System for Elevators (Schindler R.I.S.E.)** – will enhance quality and speed of construction while maintaining safety on site.



Smart operation – switching to digital

All our new elevators are fully enabled for **Schindler Ahead** – our IoT (Internet of Things) portfolio of services. With Schindler Ahead, we make sure that our customers can step confidently into the digital era.

– Maximize uptime with Ahead Remote Monitoring

With digital connectivity, issues can be detected and addressed well before service is affected. This helps facilities take timely action to minimize or even avoid downtime. Schindler Ahead maximizes uptime thanks to instant, accurate insights.

– Real-time insights with Ahead ActionBoard

Ahead ActionBoard provides operational, performance and commercial information in real time, giving customers clear, instant oversight of their entire elevator and escalator portfolio.

Elevator planning and design in minutes with Schindler Plan & Design Tool



Specifications and outputs created by Schindler Plan & Design Tool are compatible with Building Information Modeling (BIM)



Schindler R.I.S.E. enhances quality and speed of construction

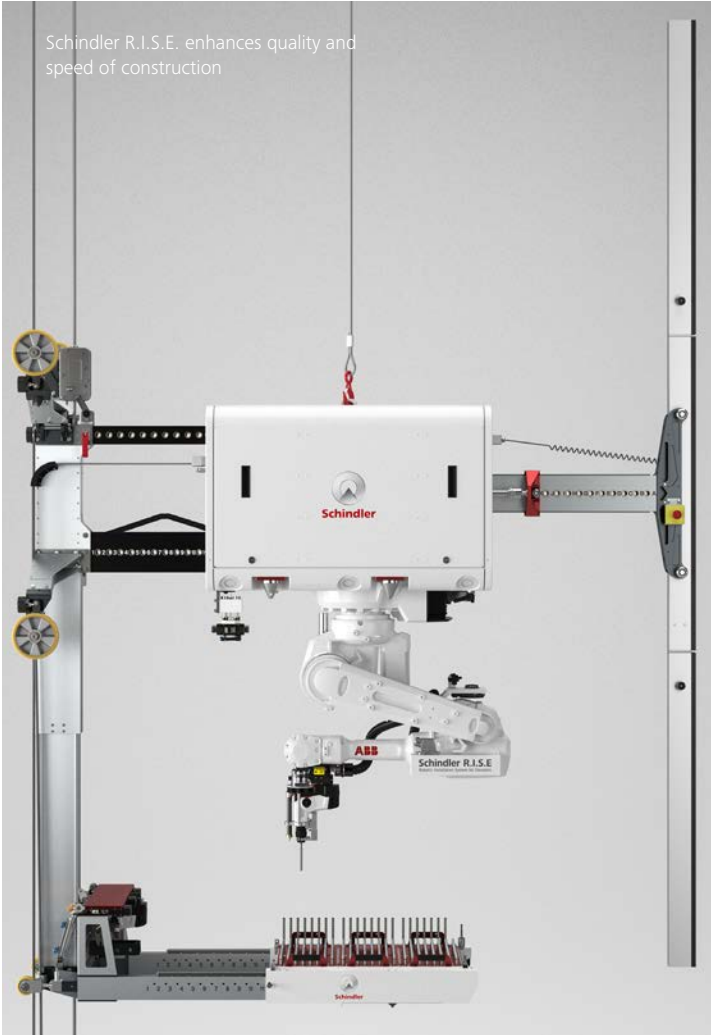

Schindler Ahead ActionBoard provides customers with performance data in real time

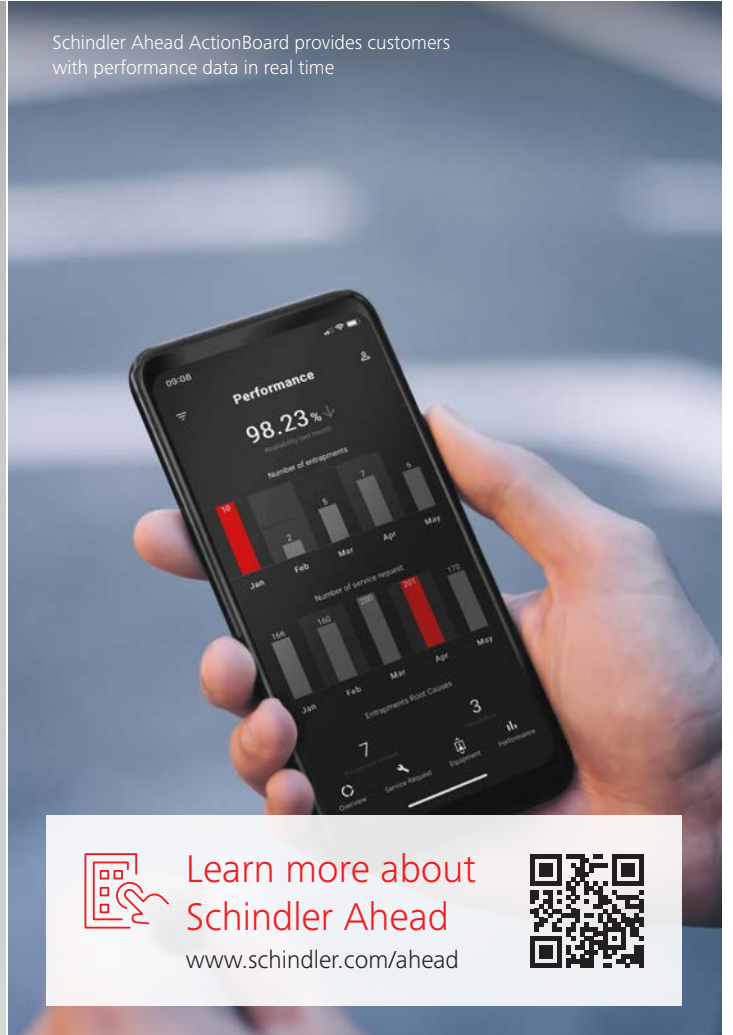

Learn more about
Schindler Ahead
www.schindler.com/ahead



Navona
Functional and durable



Times Square
Modern and versatile



Multiple design options

Ready-made interior design lines

Navona

Functional and durable

Clarity and comfort in your car with this robust design line. Fresh colors, durable accessories, and the option of five different floors make Navona an excellent choice for residential applications. Stainless steel options are also available for rear and side walls.

Park Avenue

Sophisticated and elegant

A touch of class. Wooden and textured laminates or back-painted glass walls for a rich, contemporary mode. Or a luxury feel with stainless steel in seven different finishes or decorative glass. Matched lighting completes Park Avenue's elegance.

Times Square

Modern and versatile

A contemporary look. Choose from warm or cool colors or combine to enhance contrast for more depth. Times Square adds distinctive features to any public, commercial or residential building.

Note: Specifications, options and colors are subject to change. All cars and options illustrated in this brochure are representative only. The samples shown may vary from the original in color and material.

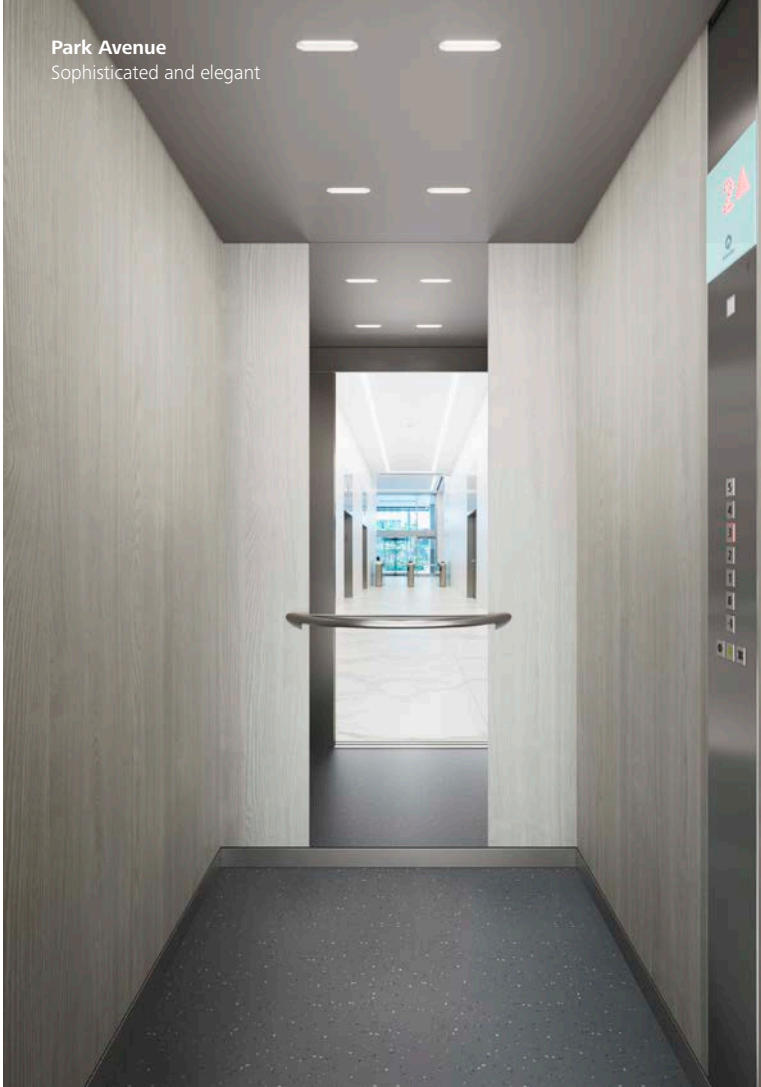

Freedom of design

Create the look and feel you like

Choose an elevator design that perfectly matches your building interior. Select from Schindler 3000's three décor lines and combine your choice with our range of operating panels, handrails, lighting, mirrors and other accessories.

And for full custom designs, the Schindler 3000 bare car option allows you to add up to 30% of the car's rated load capacity for the materials and finishings of your choice.



Design your elevator
in minutes

Explore the wide range of combinations available with our easy-to-use online Plan & Design Tool:
www.schindler.com/plan



Car operating panels and landing fixtures

Outfit your elevator with style

Linea 100

Linea 100 offers functional design in stainless steel. The integrated white glass display comes with large, easily readable red LED dot matrix floor indicator. Push buttons have clear red illumination when a call is recognized.

Linea 100 Touch

The convenience of our typical user interface converted to a touch version. The stylish design is in resistant glass with light indication to signal all functions, and dot matrix displays with large, easily readable red LEDs.

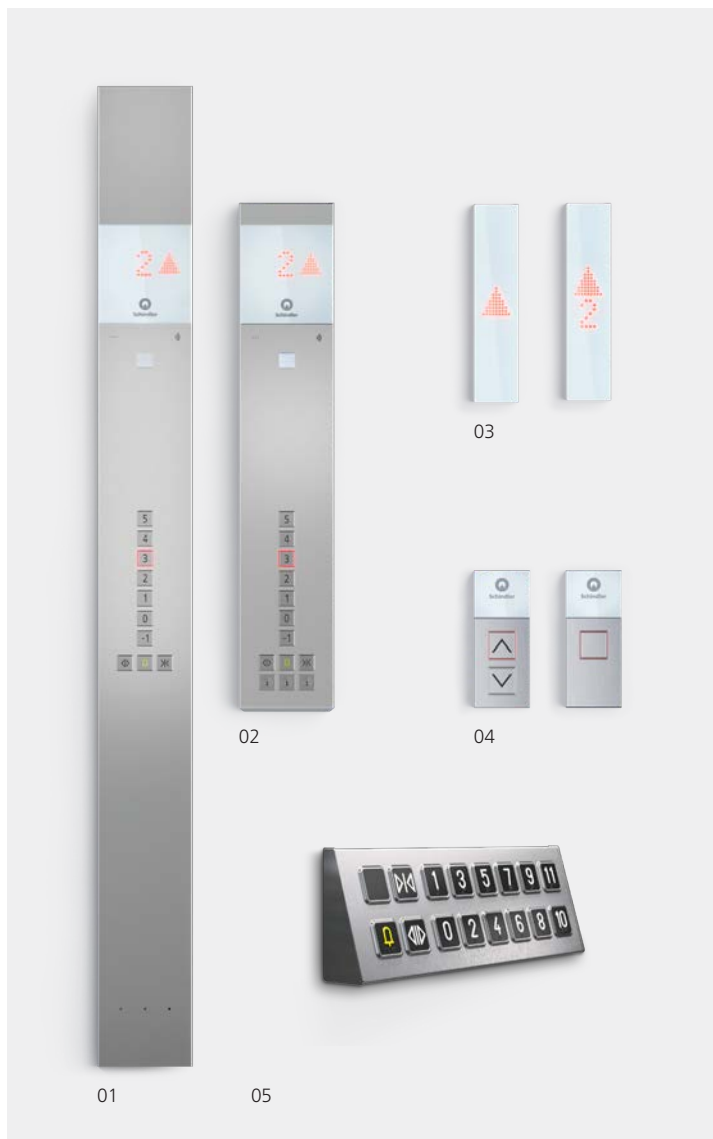

- 01 Full height car operating panel
- 02 Half height car operating panel
- 03 Car position & direction indicators
- 04 Landing operating panels
- 05 Horizontal car operating panel (EN:81-70)

- 01 Car operating panel
- 02 Car operating panel with key switch
- 03 Car position & direction indicators
- 04 Landing operating panels

Linea 300

An upmarket user interface to enhance your elevator's looks, with an intuitive, efficient design. The display is in black glass, with buttons positioned on elegant black stainless steel, or white glass display on typical stainless steel color finishing.

The PORT Terminal

The new PORT hall call destination terminals deliver brain-power to your building. A range of PORT Terminals is available, with numerous options to optimize traffic flows. Now an established reference worldwide, PORT terminals offer elegant design, stylish ergonomics and a contemporary look.



01

02

03

- 01 Full height car operating panel
- 02 Car position & direction indicators
- 03 Landing operating panels



01



02



03



04

- 01 PORT 1 black wall-mounted
- 02 PORT 1 white pedestal
- 03 PORT 4 flush black
- 04 PORT 4 flush grey

Mirrors

Ensuring optimal appearance

Mirrors enhance the sense of space, depth and comfort in elevators. Schindler 3000 elevators can be fitted with a full-height or half-height safety-glass mirror on the side or rear wall of the car.

Side wall



Half height centered



Full height centered

Rear wall



Half height centered



Half height full width



Full height middle panel

Park Avenue

Laminate Wood Portland Ash walls
Full height middle panel mirror

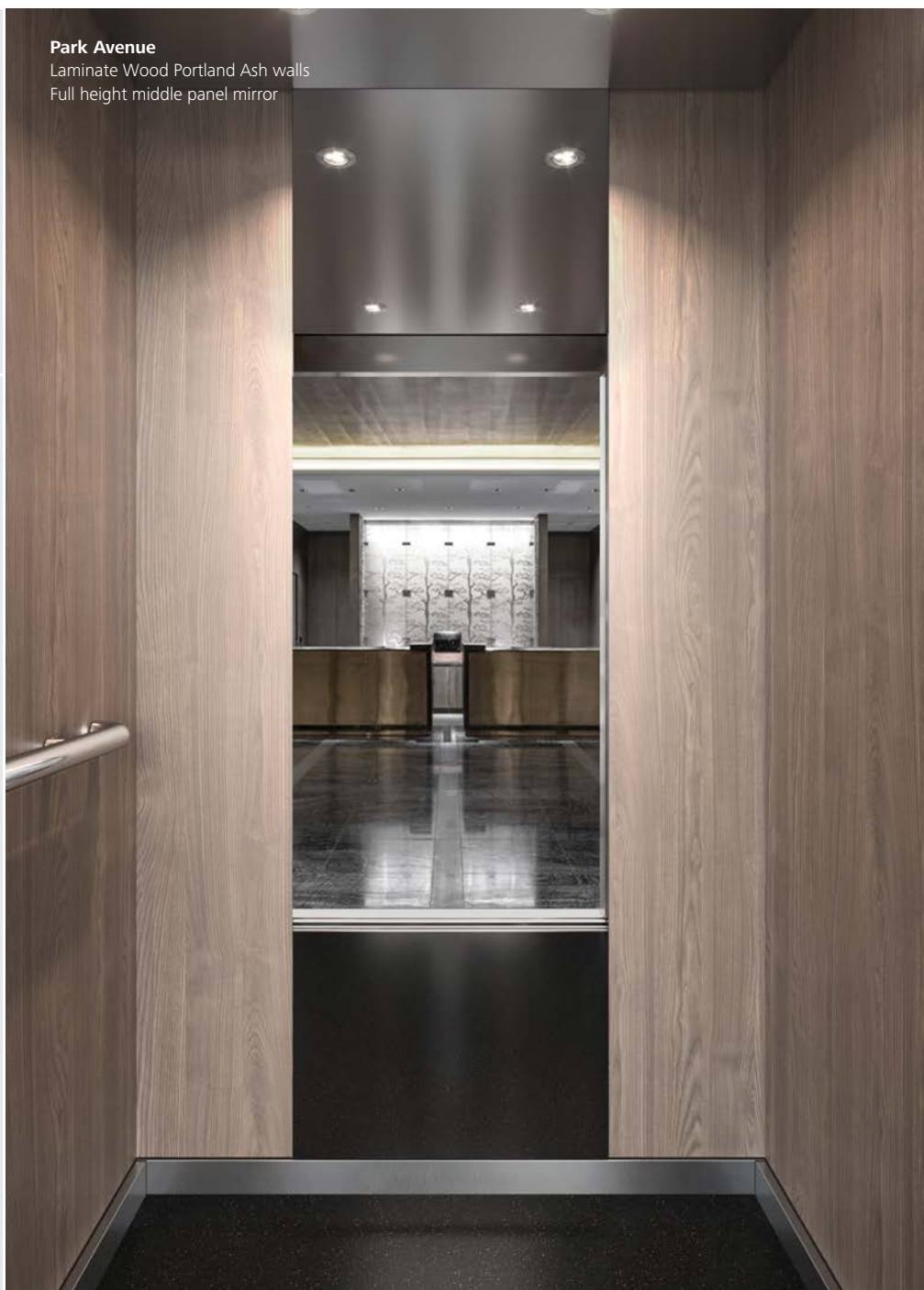

Landing doors

For a stylish entrance

How your elevator design immerses with your building can enhance your tenants' response to the overall décor design. We offer a full range of colors to help you unleash your building's full design potential.

Landing arrangements

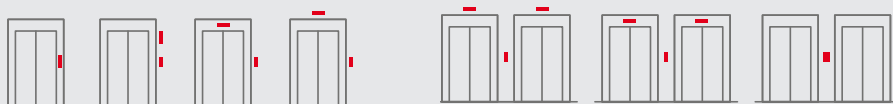

Choose your optimal landing arrangements for simple and multiplex installations, surface or wall mounting.

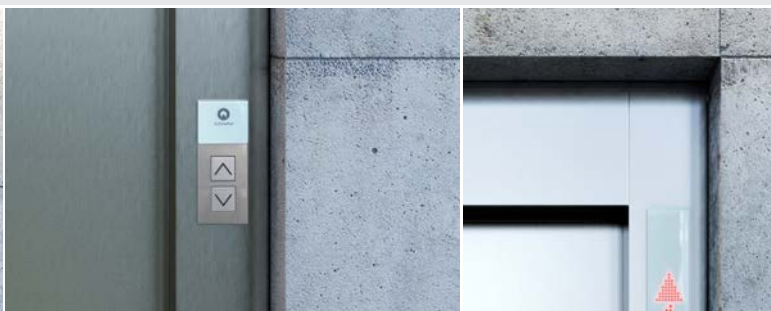

Landing door color options

- 01 Painted Pebble Grey
- 02 Painted Polar White
- 03 Painted Riga Grey
- 04 Painted Ruby Red
- 05 Painted Anthracite Grey
- 06 Stainless Steel Lucerne Brushed (441 + 304)
- 07 Stainless Steel Lasanne Linen (441 + 304)
- 08 Stainless Steel Polished Mirror (304)

Glass door frame options

- 06 Stainless Steel Lucerne Brushed (441)
- 07 Stainless Steel Lausanne Linen (304)
- 08 Stainless Steel Polished Mirror (304)

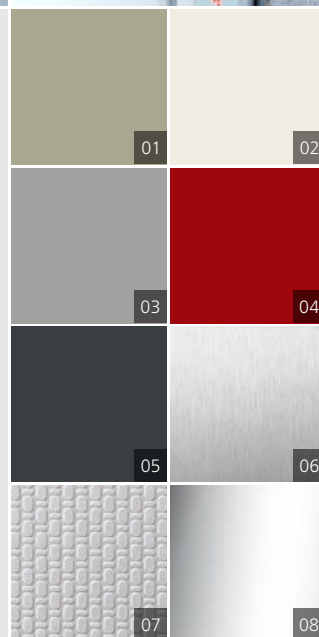

Handrails

A wide choice of shapes and finishes

Handrails convey a feeling of security. Schindler stainless steel handrails are designed to blend with car interiors, shapes and textures, and can be mounted to the side and rear walls. Available in curved, straight, straight with curved ends, and revolving layouts.

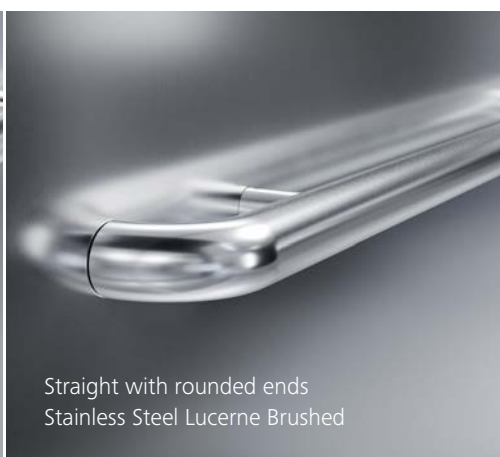

Customize your handrails

Handrails convey a feeling of security. Our handrails are designed to blend with car interiors, shapes and textures.

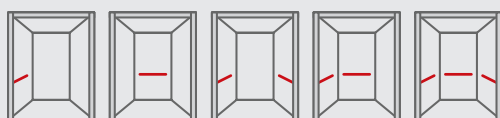

The handrails can be mounted in different combinations of side and rear walls, either only one handrail piece on the rear or side walls, two handrail pieces on the side walls or handrails on three walls. They can be connected straight or revolving.

Choose the handrail shape you prefer:

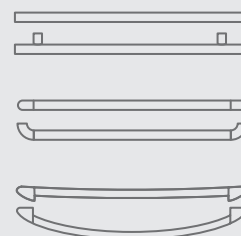

Straight, straight with rounded ends or curved

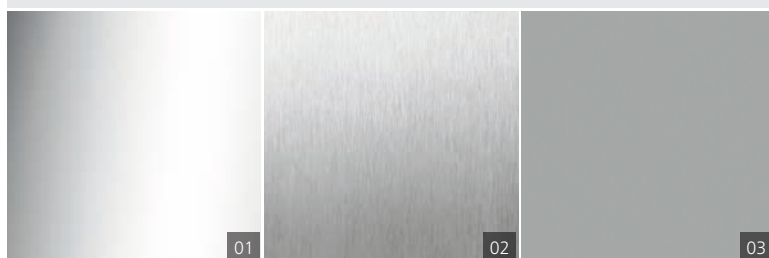

- 01 Stainless Steel Polished Mirror
- 02 Stainless Steel Lucerne Brushed
- 03 Painted Riga Grey

Bumper rails

Preserving your car interior

Designed to protect your elevator car walls and prolong their sleek looks, Schindler's damage bumper rails are available in a variety of heights, and in stainless steel, PVC or wood.

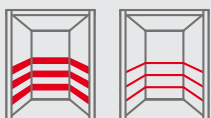

Choose from different heights depending on your requirements. Available in stainless steel, PVC or wood.

01 PVC Coated Black

02 Stainless Steel Lucerne Brushed

03 Solid Wood

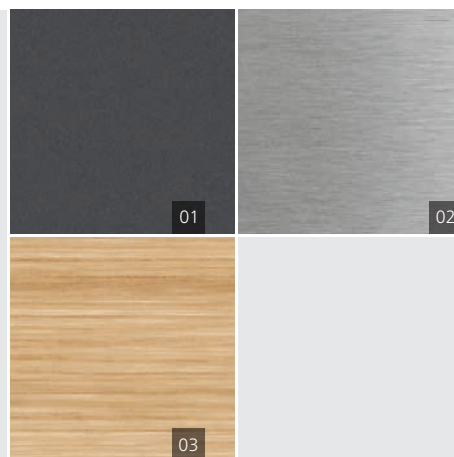

Times Square

Stainless Steel Lucerne Brushed walls
Stainless Steel Lucerne Brushed bumper rails



Schindler Plan & Design Tool

Design your elevator layout in minutes

Our easy-to-use online planning tool makes it simple to find the matching vertical transportation setup for your building. The Schindler Plan & Design tool helps you to prepare specifications in the early stages of your building's project life cycle.

With just a few clicks, we provide you with recommendations, a comprehensive product specification, and detailed layout drawings. Simply download the data straight into your project design in DWG or PDF formats.

The solution can be integrated with Building Information Modeling standards, and our Project Cloud makes it easy for you to share your projects with us.



www.schindler.com/plan

This publication is for general informational purposes only and we reserve the right at any time to alter the services, product design and specifications. No statement contained in this publication shall be construed as a warranty or condition, expressed or implied, as to any service or product, its specifications, its fitness for any particular purpose, merchantability, quality or shall be interpreted as a term or condition of any service or purchase agreement for the products or services contained in this publication. Minor differences between printed and actual colors may exist.

We Elevate



Schindler